



For Earth, For Life
Kubota

L

KUBOTA DIESEL TRACTOR L45

Sporting an HST Plus transmission and packed with power, the new L45 tractor/loader/backhoe is ideal for contractors, landscapers, rental users and homeowners seeking professional results.



**The powertrain to provide
the muscle you need.
The technologies to deliver the
versatility you're looking for.**

NEW

**HST PLUS
TRANSMISSION**



Loaded with a robust Kubota diesel engine and a high-performing HST Plus Transmission, the new L45 tractor/loader/backhoe gets the job done. Besides its world-class powertrain, the L45 features advanced technologies such as a digital panel, a slanted hood and loader boom design, and a handy backhoe crawling mode. And if that isn't enough, an easy-detach backhoe allows the use of a Category I 3-point hitch (optional) and independent PTO. With all these features, the new Kubota L45 promises to be your go-to tractor for almost any job.

KUBOTA DIESEL TRACTOR L45





Transport

Kubota makes transporting simple. Weighing in with loader and backhoe at approx. 3,254 kg*, use your 3/4-ton pick-up truck with a trailer to move the L45 from site to site quickly and easily.

**Weights may vary due to mounted options.*

TRACTOR

Whether you're hauling, loading, digging, tilling, cutting or just tooling around your work site, the L45's HST Plus Transmission and commanding 45HP diesel engine make tractor and implement operation easier.



NEW HST PLUS TRANSMISSION

With Hydro Dual Speed (H-DS), Load Sensing ability, HST Response Control and Auto Throttle Advance, the L45's HST Plus Transmission achieves superior performance by providing automated control of both the HST pump and motor.

Feather-step Operation (Hydraulic Servo System)

Our HST also comes with a smoother, more responsive pedal, thanks to Kubota's traditional hydraulic servo system, which decreases the amount of pressure required to depress the pedal.



Integrated Main Frame

The L45's integral main frame absorbs twisting loads during backhoe and loader operation and will not transmit flex to the tractor chassis. This ensures the tractor's structural integrity.



Engine

You'll experience greater power, dependability and cleaner emissions with the 45HP Kubota diesel engine. It starts quickly in cold weather and sustains high torque rise, even under heavy loads or at lower speeds. Special balancers provide lower noise and vibration levels, and a spark arrester muffler is standard equipment.

Standard Spark Arrester

Mounted under the hood of the L45, the standard spark arrester muffler helps ensure that you are safe when working around dry fields, grass or in other areas with combustible materials.

Remote Hydraulic Control Valves (Optional)

The L45 offers three optional Remote Hydraulic Control Valves for a greater selection of hydraulically powered implements. For operators, this versatile system translates into a convenient and cost-efficient solution.

Independent PTO

Our independent PTO allows you to engage and disengage the rear PTO while the tractor is in motion. So, there's no need to stop the tractor's travel to engage or disengage the rear PTO. Plus, for safer and more convenient PTO use, the L45 features auto shut-off and protective flip-up shields.

Heavy-duty Rear Axle

The heavy-duty rear axle uses multiple wet-disc brakes for extended life and smooth stopping performance.

Auto-leveling Valve

The auto-leveling valve automatically keeps the bucket or pallet fork horizontal as the loader boom raises and lowers. The On/Off switch deactivates the system for greater operator control. Spills are reduced, while pallet fork operation and loading jobs are made easier.

Lifting Capacity

The L45's productive hydraulic system means heavy-duty loads are no match for its 1,000 kg lifting capacity and 2.8m lifting height.



Front Guard

Beautiful protection. The front guard is engineered to match the L45's sleek, slanted hood and loader design.



Slanted Boom Design

Slanted to match the L45's hood, the front loader boom design provides operators with a greater field of view when changing attachments. It also gives the tractor a more sleek and modern appearance.



FRONT LOADER

Excellent operation. Better visibility. Superior versatility. These are just some of the reasons Kubota's performance-matched loaders are considered unrivaled for power and productivity. With 1,600 kg of breakout force, 1,000 kg of lift capacity and a 2.8 m lift height, these remarkable loaders have the strength and reach for most projects.



Protected Hoses

The hydraulic hoses are routed through the L45's loader boom for clearer operator views, as well as increased hose protection and durability.

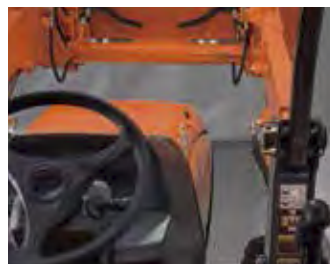

Brace-less Frame

The L45's brace-less loader frame design improves visibility over the hood, to the side and when servicing the engine. It helps you to be safer, more productive and more efficient.



Quick Coupler

The quick coupler is simple to use and dependable. Quick, easy on/off buckets and pallet forks require no tools, only mounting pins and hose couplers. So, you can move onto the next task in a matter of minutes.



Optional 3rd Function Valve

The L45 can be equipped with our optional 3rd function valve. This large-capacity (61 LPM) valve makes Skid Steer-type attachments, such as augers and sweepers, easier to operate.

Construction-grade Hydraulic Cylinders

The L45's construction-grade cylinders are built to last. Their outstanding sealing performance makes them strong and exceptionally durable. In addition, the high-quality plating of the cylinder rods offers superior rust protection.



Digging Capacity

With a 3.0 m digging depth, 25892 N of bucket breakout force and a lifting capacity of 560 kg, you'll be able to power through those tough jobs with the L45's backhoe. Large hydraulic pumps enable smooth, efficient management on demanding excavation and trenching jobs, with the least amount of effort.

BACKHOE

With the L45's HST Plus, this heavy-duty backhoe operates more effectively than ever. Combine the HST Plus with the new backhoe crawling mode and watch your productivity go up. This backhoe also boasts a 3.0 m digging depth, a standard hydraulic thumb bracket, and a high-performance inching valve.

Quick Coupler and Buckets

With our optional quick coupler, changing buckets is a snap. This is the perfect option for those who do a lot of bucket work and frequently change bucket types.

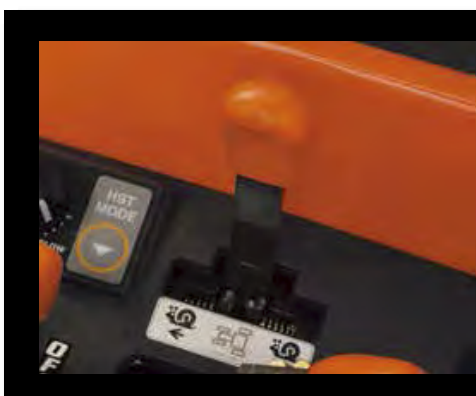

Backhoe Crawling Mode

A rare feature for this type of TLB, Kubota's backhoe crawling mode allows you to move at "creep" speed while at the controls of the backhoe. This is especially time-saving when repositioning along lengthy trenches.

Curved Boom

Now, you can avoid those dig area obstacles like rocks, and easily reach maximum dig depth with a minimum trench cut. Our curved boom design is arched to clear side boards and position materials in the center of the truck bed, while giving a more rugged look to the L45.



Auxiliary Hydraulic Valve and Thumb

Our optional auxiliary hydraulic control valve and hydraulic thumb give you greater versatility when working with the backhoe. The L45 reduces installation time with a built-in thumb bracket as standard equipment.



Enclosed Hydraulics

All hydraulic hoses are routed through the boom and arm for improved hose protection and durability, not to mention excellent visibility and an overall cleaner backhoe design.

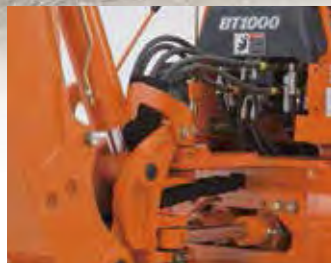

High-Performance Inching Valves & Independent Swing Pump

Our high-performance inching valves ensure accurate positioning to allow you to work in smaller increments more smoothly and efficiently. The dedicated, independent swing pump enables simultaneous swing and backhoe movement for more efficiency.



Quick-Mount Attach/Detach

Featuring a four-point mount, quick attach system, the backhoe can be removed and installed easily.



Stabilizer Lifting Height

The L45's powerful stabilizers provide maximum rear-tire lift, even while the engine is idling, ensuring optimum backhoe work performance.



IntelliPanel®

The L45's onboard system provides comprehensive tractor information. Get current working status, engine, fuel and oil warning signals, as well as maintenance indications in simple, standard indicator form.

Full Flat Deck

Our full-flat deck gives you ample legroom. This makes operation more comfortable and mounting and dismounting the tractor easy. Additionally, this deck substantially reduces vibration and driver fatigue through the use of rubber mounts.



Walk-thru Step

The generous step-thru area lets you switch from loader to backhoe operation quickly and easily. The seat pivots on the spot to eliminate operator dismounts or having to climb over the seat.

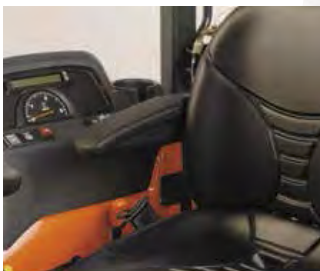

Arm Rests

The L45's arm rests help reduce arm movement and operator fatigue, especially when performing loader work.





OPERATION

The L45 wasn't just built for power and versatility; it was also designed to be comfortable for almost any operator. We've increased the width between the fenders by nearly 75 mm, and used some of that room to add armrests. The L45 also features a full flat deck for easy mounting and dismounting, as well as the always easy-to-read Intellipanel®.



Slant Nose Hood

The L45's distinctive slant nose hood design isn't just for looks. This unique styling offers you a greater field of view, allowing you to see more of what's in front of you.



3-Point Hitch Storage

Have the backhoe mounted? When not in use, pack away the optional Category I 3-point hitch linkage in our convenient storage spaces.



Four 55W Work Lights

Whether you're working at night or just in darkened places, these standard lights will provide the illumination you need. Also, two front and two rear adjustable lights are optional.

L45 TRACTOR SPECIFICATIONS

Engine	Brand, model	Kubota, V2203-M-E3-TLB1
	Type	Indirect injection vertical, water-cooled, 4 cycle diesel
	Gross power (SAE)	33.6 kW (45.0 HP)
	Net power (SAE)	31.7 kW (42.5 HP)
	Total displacement	2197 cm ³
	No. of cylinders	4
	Rated speeds	2700 rpm
Max. PTO power		23.9 kW (32.0 HP)
Fuel tank capacity		45 litres
Tire size	Front	27 x 10.5-15R4
	Rear	15-19.5R4
Rear PTO		Independent, 540 rpm
Clutch		Dry, Single
Power steering		Hydrostatic
Transmission	Type	HST Plus
	No. of speeds	Infinite
	Max. traveling speed	22.5 km/h
	Range shift lever position	Seat side, right
Brake type		Multiple wet discs
Hydraulic system	Pump capacity	94.9ℓ/min.* ²⁾
	3-point hitch lift capacity at 610 mm behind lift point	1250 kg
	Position control	Standard
3-point hitch (Category I)		Optional
ROPS		4 post, Standard
FOPS		Standard
Dimensions	Overall length (without 3P, with front guard)	2948 mm
	Overall width	1842 mm
	Overall height with ROPS & FOPS	2415 mm
	Wheel base	1841 mm
	Min. ground clearance	365 mm at transmission case
	Tread	Front 1165 mm Rear 1426mm
Min. turning radius		3.4 m
Weight with Loader, Backhoe and ROPS/FOPS*¹⁾		3254 kg

*¹⁾With round back loader bucket, 18" backhoe bucket and standard tires.

*²⁾11.8GPM for loader/backhoe, 6.6GPM for backhoe boom swing, 6.6GPM for power steering.

TL100A LOADER SPECIFICATIONS

Lift capacity to max. height at bucket bottom mid point:	1000 kg
Lift capacity to max. height at pivot pin:	1292 kg
Breakout force at pivot pin:	20153 N
Control valve:	One detent float position power beyond circuit hydraulic dual self-leveling valve
Net weight (Approx.):	472 kg
Auto-leveling mechanism:	Standard, Hydraulic
Operating Dimensions:	
A. Maximum lift height to pivot pin ...	2893 mm
B. Clearance with bucket dumped ...	2287 mm
C. Reach at maximum height	426 mm
D. Maximum dump angle	44 deg.
E. Reach with bucket on ground	1739 mm
F. Bucket rollback angle	48 deg.
G. Digging depth	89 mm
H. Overall height in carrying position	1402 mm
Performance Ratings (No Load)	
	Self-leveling on off
Raise to full height:	3.6 sec. 3.2 sec.
Lowering time self level valve:	5.8 sec. 3.5 sec.
Attachment rollback time:	1.9 sec. 1.9 sec.
Attachment dumping time:	2.2 sec. 2.2 sec.

*Tires applied: 27x10.5-15R4 (Front) and 15-19.5R4 (Rear)

BT100A BACKHOE SPECIFICATIONS

Digging force using bucket cylinder (approx.)	25892 N
Digging force using dipperstick cylinder (approx.)	16797 N
Trunnion type boom swing mechanism	Two cylinders
Operating Dimensions:	
A. Transport height	2700 mm
B. Stabilizer spread-transport	1707 mm
C. Ground clearance	312 mm
E. Overall width	1809 mm
F. Digging depth, maximum	3073 mm
G. Digging depth, 0.6 m (2 ft.) flat bottom	3048 mm
H. Digging depth, 2.4 m (8 ft.) flat bottom	2596 mm
J. Operating height, fully raised	3993 mm
K. Loading height	2319 mm
L. Loading reach	1491 mm
M. Reach from swing pivot	4087 mm
N. Swing pivot to rear axle center line	965 mm
P. Bucket rotation	180 deg.
X. Swing arc	180 deg.
R. Stabilizer spread-operating	2268 mm
A3. Angle of departure per SAE J1234...	19.2 deg.
U. Leveling angle	10.0 deg.

*The specifications are taken with KUBOTA's L45 tractor. (Tire size: 27x10.5-15R4 (Front) and 15-19.5R4 (Rear))

The company reserves the right to change the above specifications without notice.

This brochure is for descriptive purposes only. Please contact your local Kubota dealer for warranty information.

For your safety, KUBOTA strongly recommends the use of a Rollover Protective Structure (ROPS) and seat belt in almost all applications.

For complete operational information, the operator's manual should be consulted.

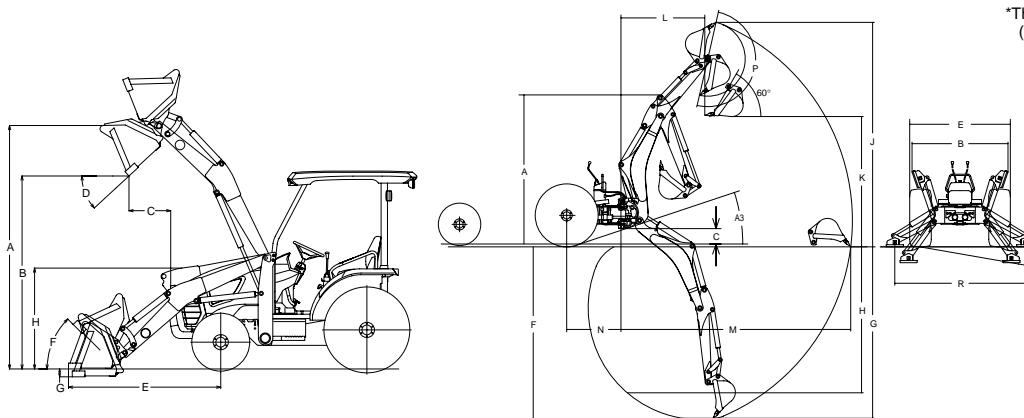

©2014 Kubota Corporation



www.kubota.co.za



Tel: +27 11 284 2000
www.smithpower.co.za

Cat.No.3255-01-SAF Printed in Japan.D.REX.'14-DEC.